

Installation & Operating Handbook



IMPORTANT NOTICE

Autohelm 5000 After Sales Service

You should receive within 10 days of purchasing this product, a warranty validation card which will enable you to obtain repair services at any of our Service Agents. In the unlikely event that this card is not received within 14 days of the date of purchase, please write to us giving the serial number of your control unit, the name of your boat and where it is normally moored, and the name of the dealer who supplied you with the pilot. Please enclose a copy of your purchase invoice. The warranty validation card will then be sent to you.

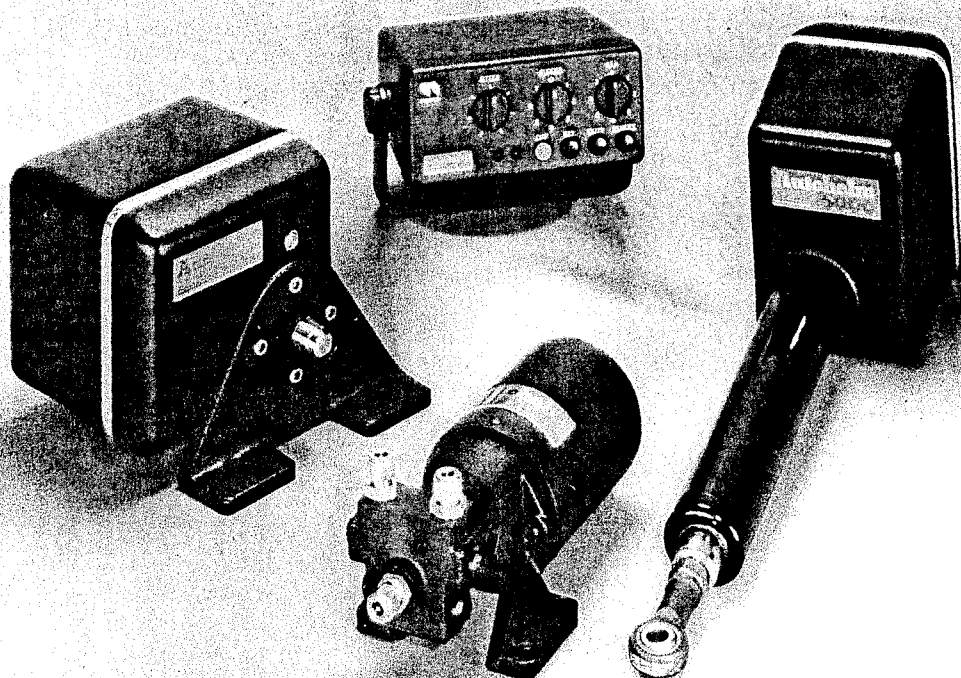

The Autohelm 5000 is a modern high performance autopilot specifically developed for sailing and motor vessels of up to 50ft (15m) LOA. It is exceptionally easy to operate and its advanced micro-electronic control circuit gives outstanding steering performance.

The Autohelm 5000 is distinguished by its automatic course locking capability which permits change-over from manual to automatic steering by a single push-button control. From then on the original heading is rigidly maintained by the automatic trim system which continuously monitors trim changes and offsets the mean wheel position to compensate. In addition, the rate of wheel rotation is regulated in proportion to the rate at which the vessel moves off course, giving the Autohelm 5000 the smooth steering capability of an experienced helmsman.

The basic system comprises a Drive Unit and Control Unit inter-connected by a pluggable multi-core cable. A complete range of optional remote control accessories are available which are also pluggable to the Control Unit. After fitting the system it is only necessary to make a single adjustment to the Control Unit in order to match the system's response range to the character of a particular vessel.

The Autohelm 5000 is exceptionally easy to install and prepare for sea trials. Sound installation however is vital if the system's high standard of performance and reliability is to be achieved. The installation notes should be followed carefully and in cases where special advice may be needed you are encouraged to contact our Technical Sales Department where expert assistance is always available.



**Autohelm
5000**

Contents

1.0	System description	3
1.1	Control System	4
1.1.1	Control Unit	4
1.1.2	Remote Control Accessories	5
1.1.3	Auxiliary Control Unit	5
1.1.4	Remote Control Unit	5
1.1.5	Remote Socket	5
1.1.6	Vane Socket	6
1.1.7	Cable Extension	6
1.1.8	Table of Catalogue Numbers	6
1.2	Drive Systems	6
1.2.1	Rotary Drive Unit	6
1.2.2	Linear Drive Unit	7
1.2.3	Hydraulic Drive Unit	7
2.0	Installation	8
2.1	Control System	8
2.1.1	Control Unit	8
2.1.2	Auxiliary Control Unit	8
2.1.3	Hand-held Remote Control System	8
2.1.4	Wind Vane attachment	8
2.2	Drive System	8
2.2.1	Rotary Drive Unit	9
2.2.2	Linear Drive Unit	10
2.3	Cabling and power supplies	11
2.3.1	Signal cabling	11
2.3.2	DC supply cable	11
3.0	Operation	12
3.1	Basic principles	12
3.2	Controls	12
3.2.1	Control Unit	12
3.2.2	Auxiliary Control Unit	14
3.2.3	Remote Control Unit	14
4.0	Functional test procedures	14
4.1	Main Control Unit	14
4.2	Auxiliary Control Unit	14
5.0	Sea trials	15
5.1	First trials	15
5.2	Rudder control adjustment	15
5.2.1	Planing craft	15
5.2.2	Displacement power vessels	15
5.2.3	Sailing craft	15
5.3	Setting the wind vane	15
5.4	Tacking under wind vane control	15
6.0	Operating hints	16
7.0	Routine maintenance	16

1.0 System Description

The Autohelm 5000 is a modular system that can be built up from a minimum number of standardised units to match the individual requirements of a wide range of sailing and power vessels. The rudder drive system may be chosen from a range of rotary, linear and hydraulic drive units to best suit the vessel's particular steering system.

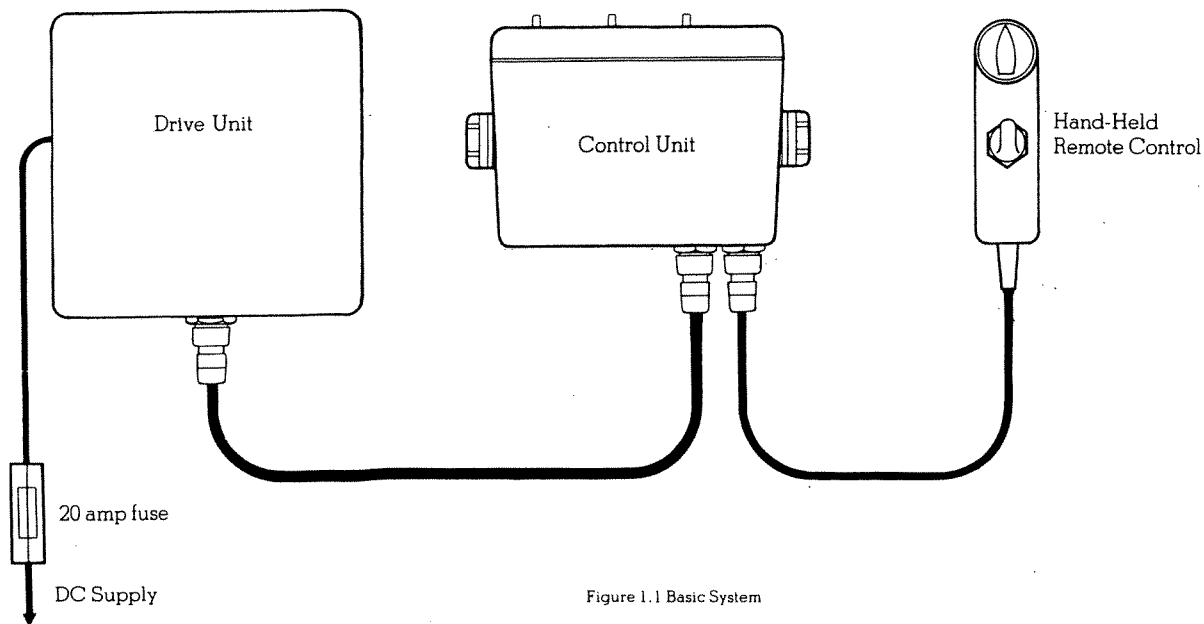

Figure 1.1 Basic System

The most basic installation is illustrated in fig. 1.1 and consists of a control unit inter-connected by a pluggable cable system to a drive unit. This installation would be suitable for a motor vessel with a single enclosed steering position, and where no requirement exists for remote control facilities. Hand-held remote control unit type D73 may be plugged directly into the Control Unit auxiliary socket.

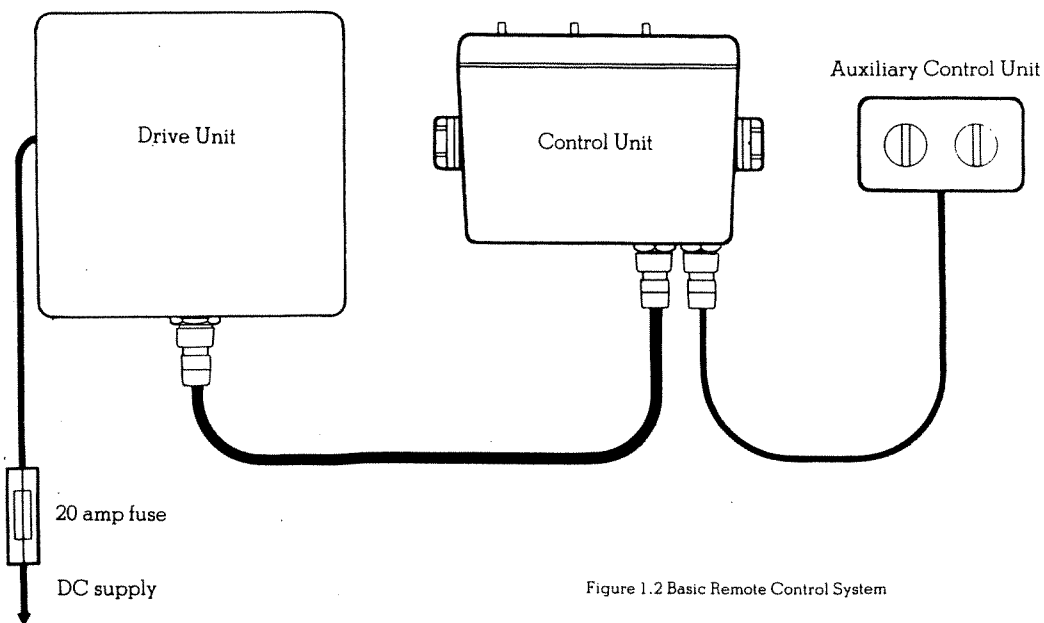

Figure 1.2 Basic Remote Control System

A simple remote control installation is illustrated in fig. 1.2. The auxiliary control unit repeats the basic working controls of the main control unit and is suitable for extending autopilot control to a secondary steering position. Alternatively, in the case of a sailing yacht for example, the auxiliary control unit provides a watertight cockpit control enabling the control unit to be mounted in a protected position below deck.

The full remote control system is illustrated in fig. 1.3 and provides the addition of a hand-held remote control unit as well as a wind vane attachment for sailing vessels. The waterproof jack sockets for the hand-held remote control unit and the wind vane attachment may be sited to minimise the length of above deck flying leads.

The standard 'A' type electronic wind vane attachment is compatible with the Autohelm 5000 and connects directly to the waterproof vane socket. Change-over from magnetic to wind direction sensing is effected by the auxiliary control unit.

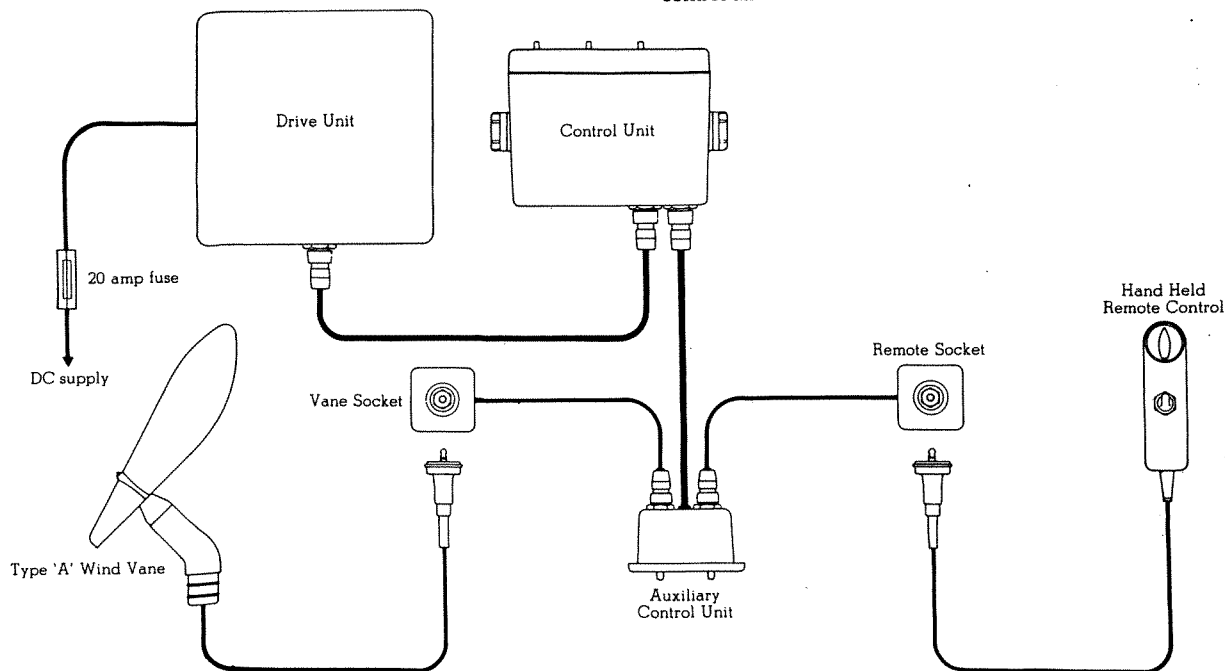
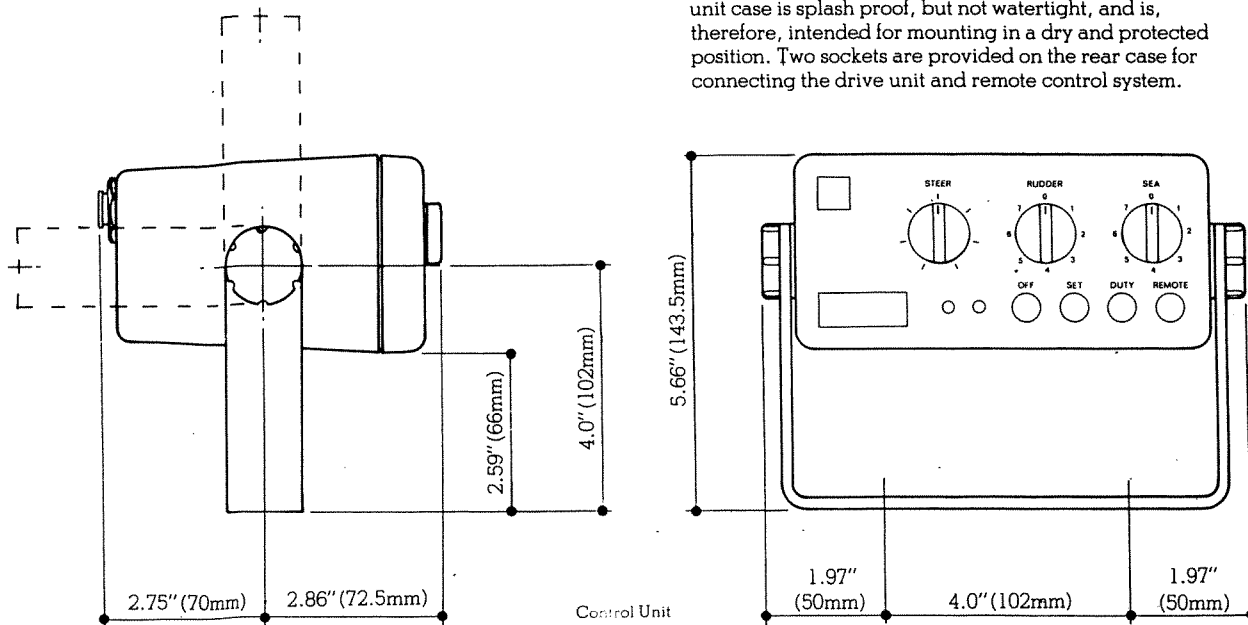

Figure 1.3 Full Remote Control System

1.1 Control System

1.1.1 Control Unit

The control unit is common to all installations and is provided with six metres of multi-core cable with pre-connected plugs and sockets to connect to the drive unit. It houses the main control circuit PCB together with the automatic course following compass system. The control unit case is splash proof, but not watertight, and is, therefore, intended for mounting in a dry and protected position. Two sockets are provided on the rear case for connecting the drive unit and remote control system.



Rotary controls for course alteration, rudder response and sea-state are grouped on the control unit facia, together with the push-button primary working controls. A secondary gain control is inset into the rear case to allow adjustment of the system's rudder response range to match the widely differing steering characteristics of both planing and displacement vessels. The control unit is suitable for use on both 12 and 24volt systems.

1.1.2 Remote Control Accessories

1.1.3 Auxiliary Control Unit

Autopilot control may be transferred to the auxiliary control unit by depressing the **Remote** push-button on the main control unit facia. The auxiliary control unit is watertight and designed for flush mounting in severely exposed positions.

It is provided with six metres of cable terminated in a waterproof plug for direct connection to the control unit. Two connectors are situated on the rear case for connecting both the vane and hand held remote control deck sockets.

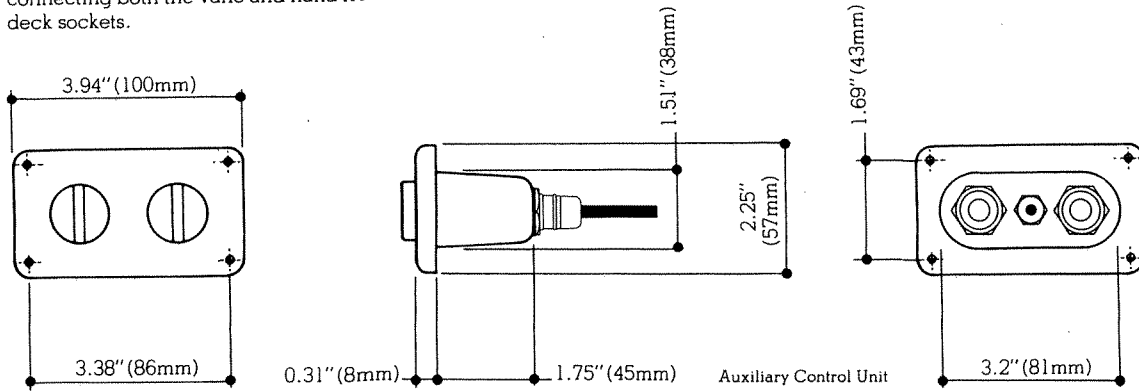

1.1.4 Remote Control Unit

The remote control is a hand-held unit that enables the autopilot to be overridden and the vessel to be power steered from anywhere on board. The unit is fitted with a six-metre flying lead Type D73 is suitable for direct connection to the Control Unit auxiliary socket. Type D55 is fitted with a waterproof jack plug for connection to a waterproof deck socket.

1.1.5 Remote Socket

The remote socket provides a watertight flush mounting jack socket for the hand-held remote control. The socket is supplied with 6 metres of 3 core cable terminating in a plug for direct connection to the Auxiliary Control Unit.

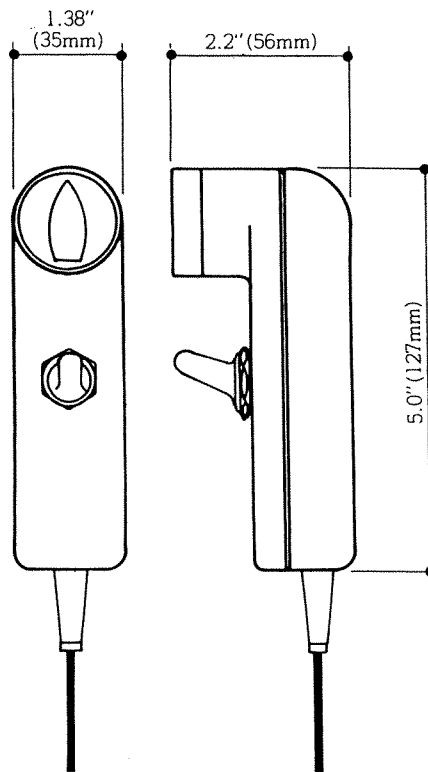
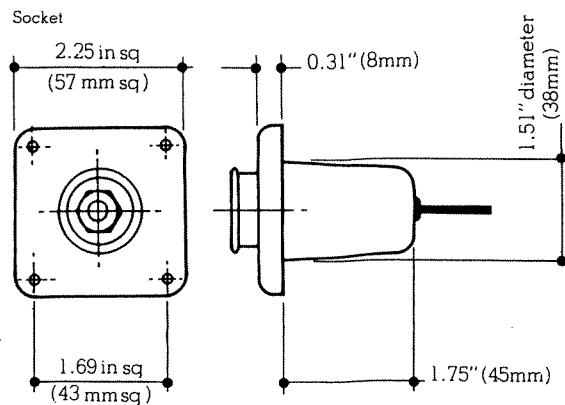

Hand Held Remote Control Unit

1.1.6 Vane Socket

The vane socket provides a watertight through-deck connection for the electronic wind vane attachment, and connects directly to the Auxiliary Control Unit

1.1.7 Cable Extension

The cable extension facilitates the lengthening of all multi-core cables in six-metre increments. The extension cable is terminated with compatible waterproof connectors for insertion into the cable harness in the positions shown in fig. 1.3.

1.1.8 Table of Catalogue Numbers

CONTROL SYSTEMS		
Control Unit	Z9	
Auxiliary Control Unit	D69 Power	
Auxiliary Control Unit	D70 Sail	
Remote Control	D55	
Direct Remote Control	D73	
Remote Socket	D71	
Vane Socket	D72	
DRIVE SYSTEMS		
	12v	24v
Rotary	Z10	Z11
Linear		
Type 1	Z12	Z13
Type 2	Z14	Z15
Hydraulic		
Type 1	Z16	Z17
Type 2	Z18	Z19

1.2 Drive Systems

Mechanical steering linkages may be driven either by a rotary or linear drive unit. Some steering systems are already fitted with a rotary autopilot drive shaft, and in such cases the choice of a rotary drive unit becomes obvious. In general, if a convenient rotary drive shaft exists and lost motion does not exceed 5% of total rudder movement the rotary drive unit becomes the natural choice. In all other cases the linear drive unit usually provides the simplest installation since it does not drive through the steering linkage, and may be connected directly to the rudder stock. Total independence of the mechanical steering linkage also means that the linear drive unit may be used to power steer the vessel in the event of steering gear failure. In addition, minimisation of working parts improves the overall efficiency of the system and reduces lost motion to an absolute minimum.

All vessels fitted with hydraulic steering systems will require one of the hydraulic drive systems.

1.2.1 Rotary Drive Unit

The output shaft is driven by an efficient permanent field motor through a spur reduction gearbox. The gearbox is ruggedly constructed and grease lubricated to permit

operation in any attitude. A fail safe friction clutch is situated in the gear train to disengage the drive when the autopilot is not in use. The clutch automatically engages when the autopilot is switched to **Duty** and will disengage instantly even under extreme load when the autopilot is switched off. Rudder movement is monitored by a tachogenerator geared directly to the output shaft to provide a velocity feedback signal. The entire mechanical assembly is housed in a compact diecast case which also contains the solid state drive amplifier. The drive amplifier incorporates a high speed current trip which regulates peak armature current and also eliminates the need for end limit switches.

Supply voltage 12 volts dc (24 volts optional).

Power consumption

1.5-2.5 amperes (at 12 volts) typical average.

Peak output torque 240lb-ins (27Nm).

Maximum shaft speed 18 rpm.

Suitable for craft typically up to 50ft (16m) LOA (and above with light steering).

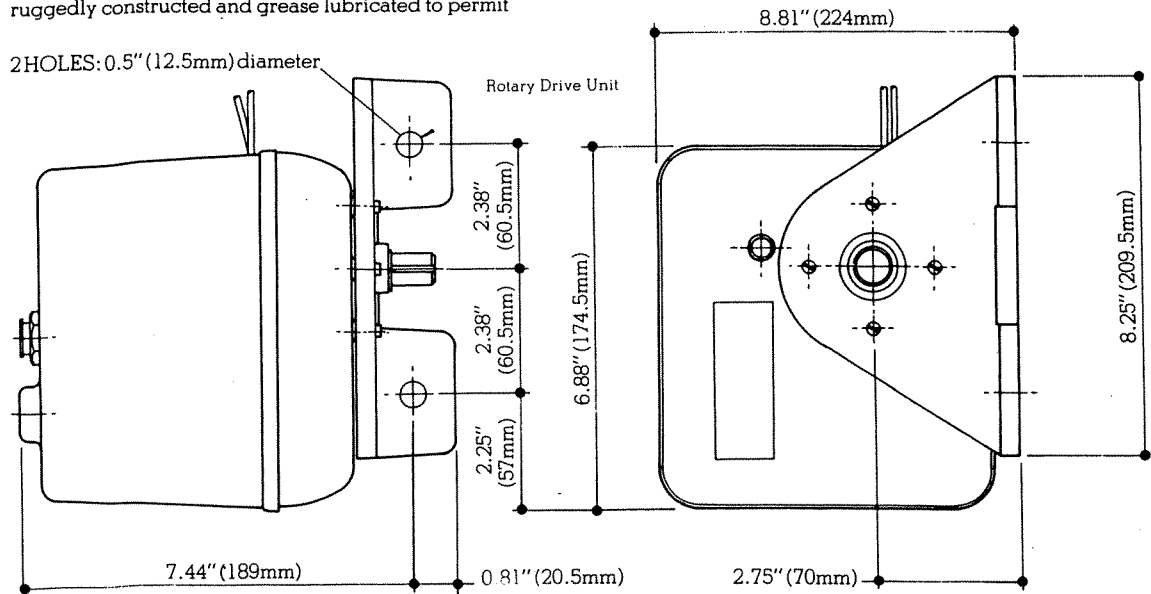

1.2.2 Linear Drive Unit

The push-pull output ram is driven by a unique declutchable recirculating ball leadscrew system which enables the drive unit to be permanently coupled to the rudder stock via a simple crank or tiller arm. The drive is automatically engaged by means of a friction clutch when the autopilot is switched to 'duty' and will disengage instantly even under heavy load when the autopilot is switched off. The system is splash proof but not watertight, and should therefore be mounted in a reasonably protected position. The drive system is housed in a rugged diecast case which also contains the solid state drive amplifier. The drive amplifier incorporates a high speed current regulator which regulates peak thrust to a safe working level and eliminates the need for end limit switches.

Supply voltage 12 volts dc (24 volts optional).

Power consumption

1.0-2.0 amperes (at 12 volts) typical average.

Maximum thrust 500lbs (225kgs).

Maximum stroke speed 1.2 in/sec (3cm/sec).

Stroke end limit

Internal mechanical buffers and electronic current limit trip.

Type 1

Suitable for craft typically up to 50ft (16m) LOA with 'normal' steering loading.

Type 2

Suitable for craft up to 50ft (16m) LOA and above with heavier steering loading.

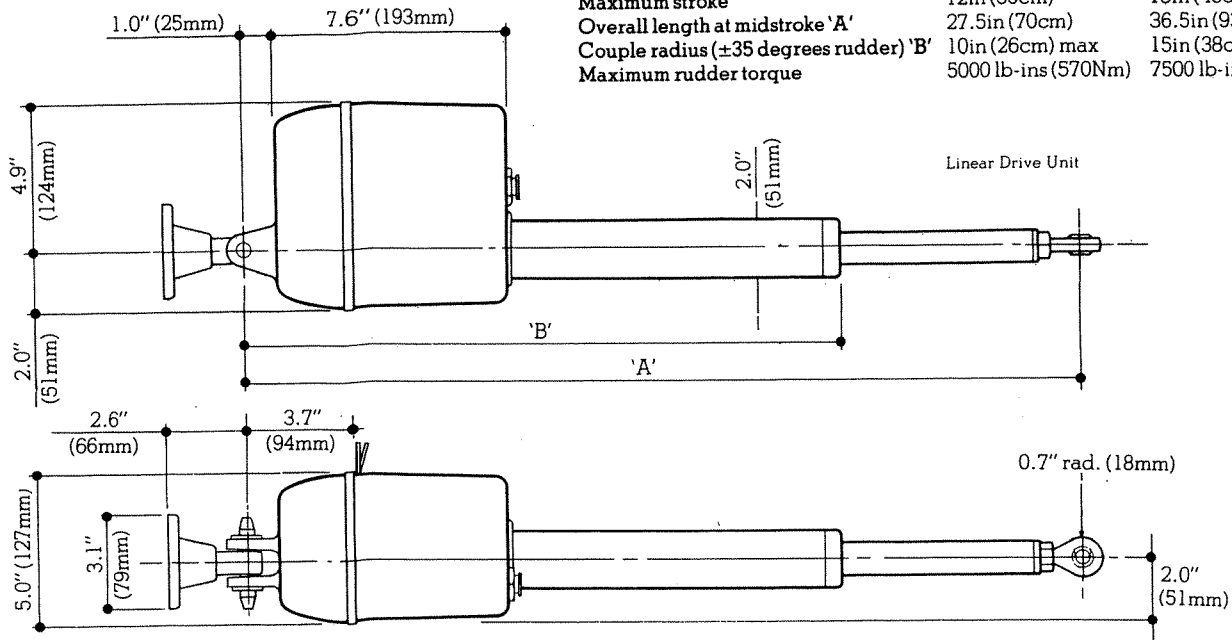

Maximum stroke

Overall length at midstroke 'A'

Couple radius (± 35 degrees rudder) 'B'

Maximum rudder torque

Type 1

12in (30cm)

27.5in (70cm)

10in (26cm) max

5000 lb-ins (570Nm)

Type 2

18in (46cm)

36.5in (93cm)

15in (38cm) max

7500 lb-ins (860Nm)

1.2.3 Hydraulic Drive Unit

The precision pump of a hydraulic drive unit permits the rate of rudder application to be proportionately regulated by motor speed control. A specially developed pressure balance valve corrects the effects of hydraulic slip and isolates the pump from the steering circuit when the autopilot is not energised. The drive motor is proportionally driven by a separately mounted solid state power amplifier which ensures that the rudder is smoothly applied and that power consumption is minimised. The drive amplifier also incorporates a high speed current regulator which controls maximum pump pressure and eliminates the need for end stroke limit switches. Installation is further simplified by the elimination of a separate rudder feedback device.

Type 1

Suitable for craft typically up to 45ft (15m) LOA with hydraulic steering ram capacity up to 25 cu in (400cc).

Nominal peak flow rate 45cu in/min (750cc/min).

Power consumption 1.5-2.5 amps (average).

Overall length 'A' 9.5in (240mm).

Type 2

Suitable for craft generally over 45ft (15m) LOA with hydraulic steering ram capacity up to 50 cu in (800cc).

Nominal peak flow rate 100 cu in/min (1500cc/min).

Power consumption 2.5-4.5 amps (average).

Overall length 'A' 11.5in (290mm).

Supply voltage 12 volts dc (24 volts optional)

Regulated peak pressure 450 lbs/in² (30 Bar)

Flow control

Integral pilot check and pressure balance valve

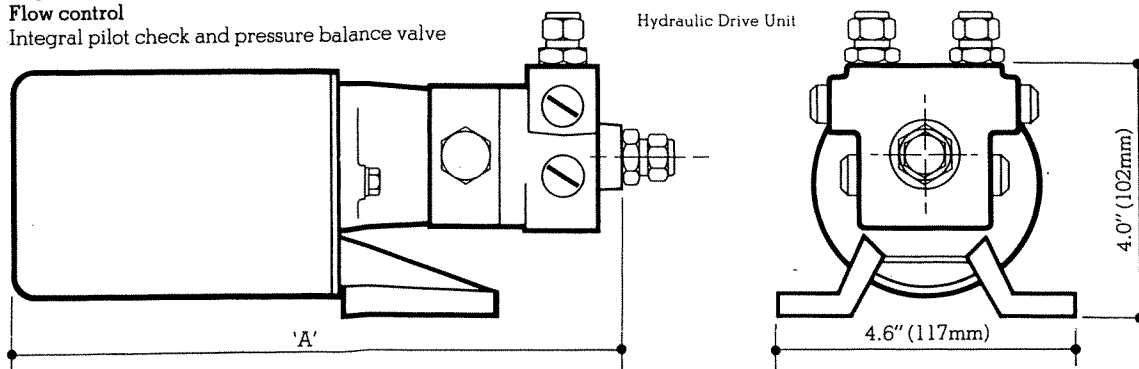

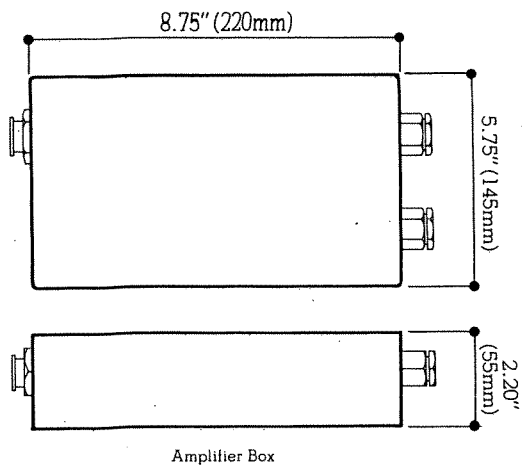

2.0 Installation

The Autohelm 5000 is exceptionally easy to install and prepare for sea trials. Sound installation however is vital if the system's high standard of performance and reliability is to be achieved. The installation notes should be followed carefully and in cases where special advice may be needed you are encouraged to contact our Technical Sales Department where expert assistance is always available.

2.1 Control System

2.1.1 Control Unit

The control unit is the most sensitive part of the system and care should be taken to select a mounting position that is reasonably free from vibration and protected from external weather conditions. The control unit is mounted in an aluminium frame which can be pivoted to permit fixing to either horizontal or vertical surfaces. The frame is finally fixed into position by two No.8 (4mm) diameter countersunk head stainless steel or brass screws.

In the case of a vessel with an enclosed wheelhouse, it would normally be desirable to mount the control unit sufficiently near to the wheel so that the controls are easily accessible to the helmsman. However, since the control unit incorporates a magnetic compass it is necessary to position it at least 2ft 6in (80cm) away from the nearest steering compass in order to avoid deviation of both compasses. Deviation of the control unit compass is much less critical because of its auto-following capability. Nevertheless excessive deviation should be avoided as far as possible in order to maintain uniform sensitivity on all headings. The control unit should thus be mounted as far away as possible from iron or other magnetic devices. If any doubt exists, the chosen site should be checked by means of a handbearing compass. The handbearing compass should be fixed into the chosen position and the vessel swung through 360 degrees. Relative differences in reading between the handbearing compass and the main steering compass should not vary by more than 20 degrees.

In rare cases even the above extreme deviation tolerance may not be achievable, in which case an alternative site remote from the steering position must be selected. In such a case it will be necessary to operate the autopilot through an auxiliary control unit situated near the steering position. Installation in steel hulled vessels invariably presents difficulties and the advice of a compass adjuster should always be sought.

Sailing yachts with a single external steering position are a special case where it is essential to operate the autopilot via a weather-proof auxiliary control unit. The auxiliary control unit would normally be mounted in the cockpit adjacent to the steering position and the control unit situated below in a suitably protected position.

The compass within the control unit is capable of satisfactory operation at roll and pitch angles of up to $\pm 30^\circ$ degrees. The control unit should, therefore, be positioned as near to horizontal as possible to maximise gimbal action in all directions. In the case of a sailing yacht where sustained heel angles may on occasions exceed the above limit, it will be necessary to readjust the control unit to a near horizontal position on each tack. To facilitate this, the control unit's suspension frame should be mounted parallel to the direction of the heel axis.

2.1.2 Auxiliary Control Unit

The Auxiliary Control Unit is connected directly to the auxiliary connector on the Control Unit. The unit is waterproof and should be positioned close to the steering wheel. It is designed for discreet flush mounting and a pattern is provided to assist panel cutting before fitting. Matching black self-tapping screws are provided to secure the auxiliary control unit facia in position. A good quality silicone sealant should be used to seal between the facia and the mounting panel.

2.1.3 Hand-Held Remote Control System

It is usually desirable to arrange for operation of the hand-held control unit from anywhere on deck. For this purpose up to two remote sockets may be strategically positioned to make this practical without the need for long and potentially hazardous flying leads on the hand-held unit. In the case of a sailing yacht for example, one socket position in the foredeck area and another in the cockpit usually makes a perfect arrangement. The sockets are flush mounted and a pattern is provided to simplify panel cutting. Matching black self-tapping screws are also supplied. A good quality silicone sealant should be used to seal the joint between the socket facia and the mounting face. When more than one remote control socket is required, the three core inter-connecting cables may be paralleled together using a standard cable junction box before connection to the Auxiliary Control Unit.

2.1.4 Wind Vane Attachment

The electronic wind vane attachment is normally mounted centrally on the after rail where it will be sited in clear wind on both tacks. The wind vane mounting mast is clamped to the after rail by the two 'U' bolts provided as shown in fig. 2.1. The wind vane head is plugged into the top of the mast after first threading through the flying lead and jack plug. The waterproof vane socket enables the vane head to be removed from the mast when not in use and provides a convenient watertight through deck connection. The wind vane socket should be positioned adjacent to the wind vane attachment and fitted as described in section 2.1.3

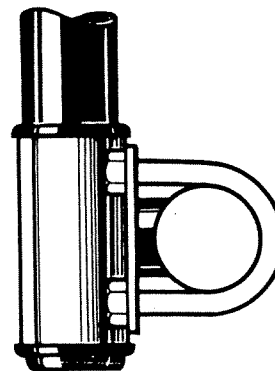

Figure 2.1 Wind Vane Mast Clamp

2.2 Drive System

The following notes describe the installation of both the rotary and linear drive units. Installation of the hydraulic drive system is described in a separate handbook supplied with each unit.

2.2.1 Rotary Drive Unit

The rotary drive unit is coupled to the vessel's steering mechanism by a simple chain drive. Most steering gear manufacturers supply special autopilot drive attachments and many include this facility as standard.

Figure 2.2 shows recommended rudder hardover to hardover times for both planing and displacement vessels up to 50 feet (15m) LOA. The charts shown in fig. 2.3 enables the chain reduction ratio for optimum rate of rudder application to be selected for both planing and displacement vessels. To use the charts, it is first necessary to determine the number of turns of the driven sprocket when the rudder is driven from hardover to hardover.

Example: A 40 foot (12m) LOA displacement vessel requiring two turns of the driven sprocket to drive the rudder from hardover to hardover will require a chain reduction ratio of approximately 3:1 (as indicated by the dotted line on the chart). The table on the left hand side of the chart gives suitable sprocket combinations. In this example, the required reduction ratio of 3:1 would be best achieved by a 38 tooth sprocket driven by a 13 tooth sprocket on the drive unit.

It should be borne in mind that the reduction ratios recommended are for the 'average case' and that vessels broadly classified by length and hull type can vary significantly in steering characteristics. Selection of the correct chain reduction ratio is not over critical however, and any slight mismatch can usually be corrected later during sea trials by an adjustment to the gain control on the control unit.

Standard 3/8" pitch chain is recommended for the chain drive. Sprockets of 13, 15, 17, 19 and 25 teeth are available as standard accessories. Bore and keyway dimensions for the drive unit sprocket are detailed in fig. 2.4. If sprockets other than those supplied by Nautech are fitted, it is essential that bore and keyway dimensions specified in fig. 2.4 are strictly adhered to. The recommended driven sprockets tabulated in fig. 2.3 are common standard sizes and should be obtainable from local suppliers of chain drive equipment. All sprockets must be 'keyed' and grub screwed to their shafts, and finally secured with 'Loctite'.

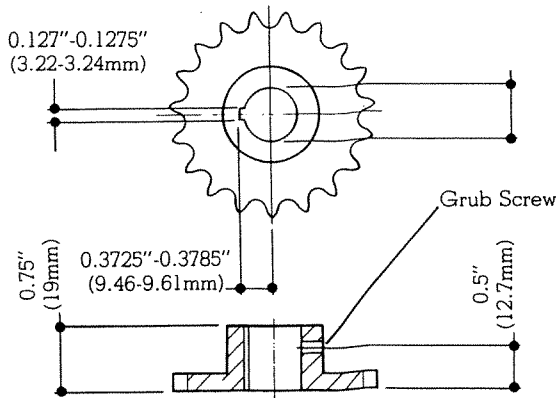

Figure 2.4 Sprocket Keyway Dimensions

The drive unit is mounted by bolting to a substantial frame member. The 'L' shaped mounting foot is secured by four equally spaced caphead screws, and may be rotated through 90 degrees to provide a more convenient mounting position if required. In some cases, it may be necessary to fabricate a special frame to mount the drive unit. It should be noted that chain tension can exceed 300lb (150kg), and thus an extremely rigid mounting structure is vital to maintain good chain alignment. Installation failures frequently occur in this area, and as a general rule it is desirable to 'over engineer' the drive unit mounting.

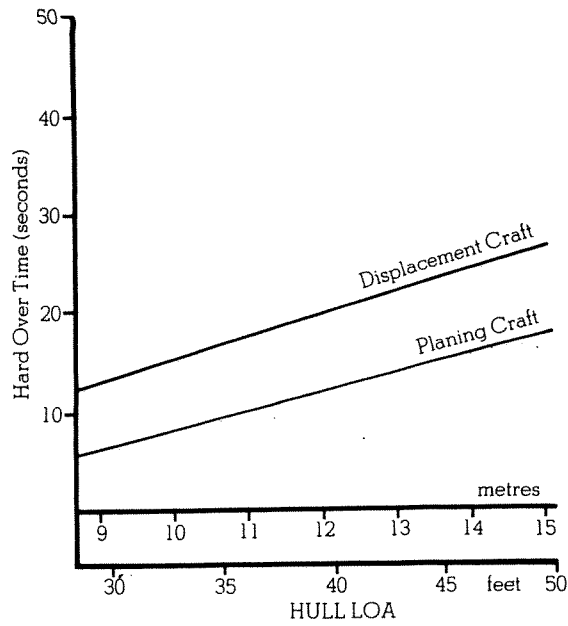

Figure 2.2 Hard Over Times

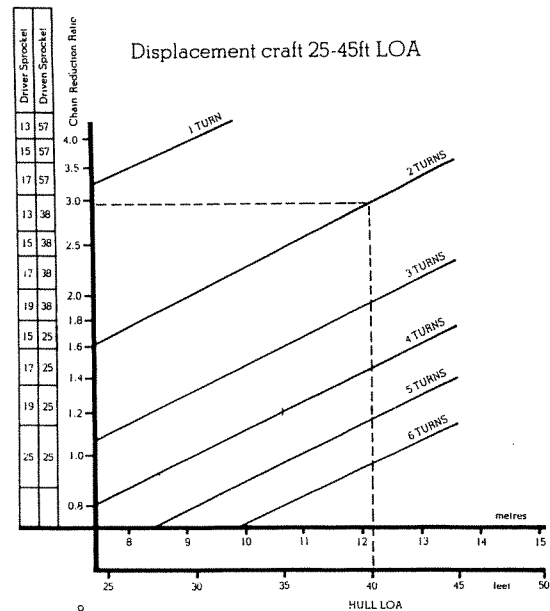

Figure 2.3a Sprocket Selection Chart

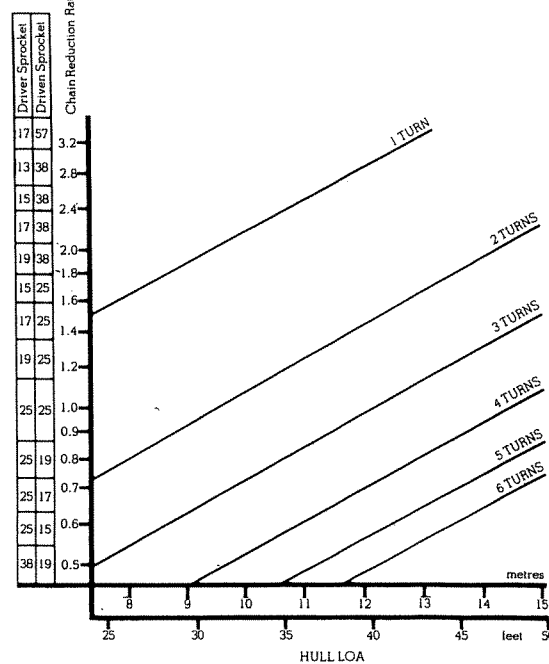

Figure 2.3b Sprocket Selection Chart

ALASKA BEARING 276-1406 133 POST RD.

Provision must also be made for chain adjustment, which is most easily achieved by removable shims placed under the mounting foot, or by elongated clearance holes in the mounting frame as illustrated in fig. 2.5. Both sprockets must be accurately aligned to run in the same plane, and this must be carefully checked by means of a straight-edge.

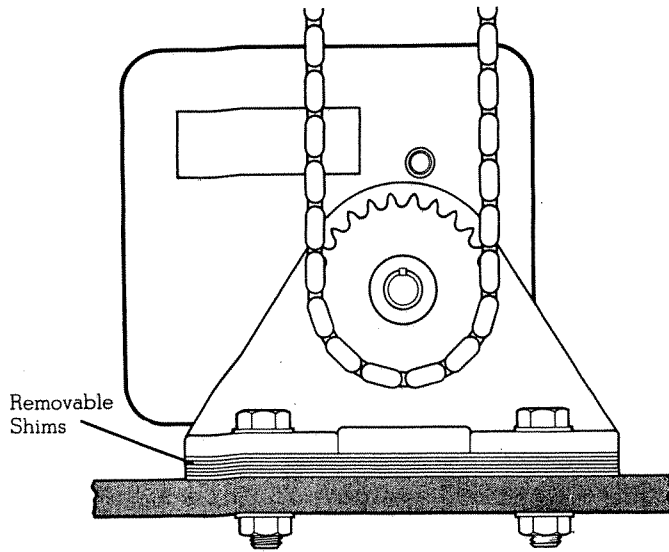
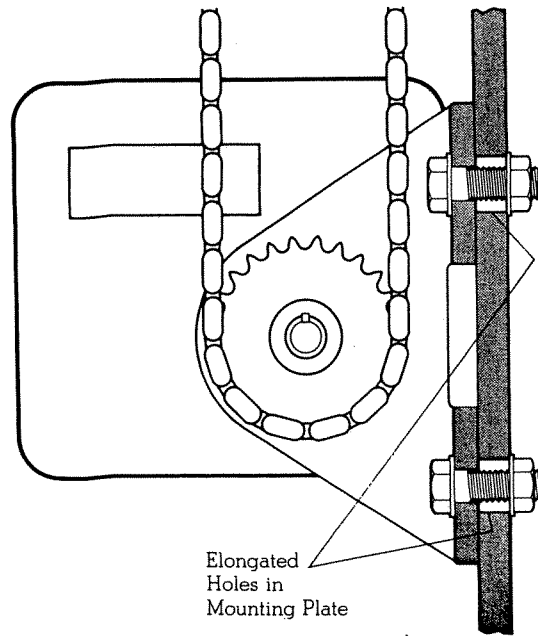

Figure 2.5 Chain Adjustment Methods



cases, however, it may be possible to couple the pushrod to the same tiller arm or rudder quadrant employed by the main steering linkage. It is important to note that the Linear Drive system can exert a thrust of up to 500lbs. If any doubt exists about the strength of the existing tiller crank or rudder quadrant the steering gear manufacturer should be consulted.

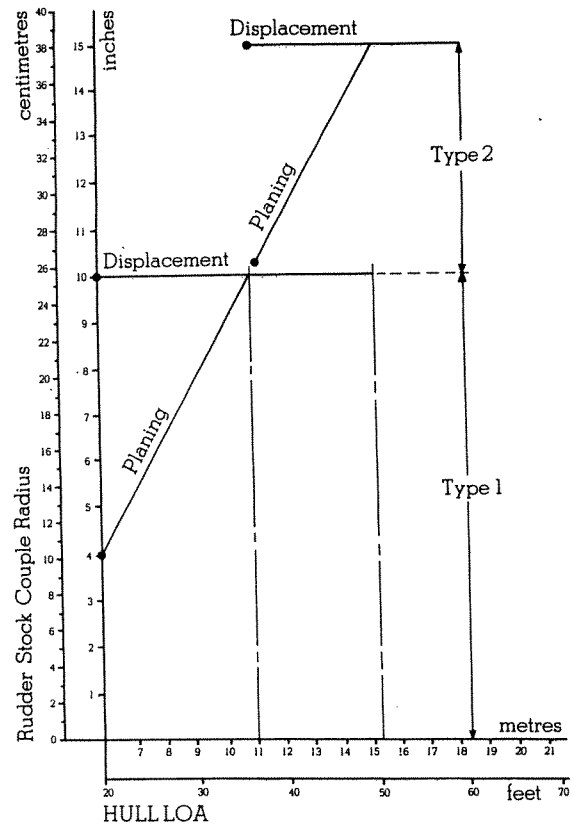

Figure 2.6 Recommended Couple Radius Chart

The method of bolting the pushrod ball end to the tiller arm or rudder quadrant is illustrated in Fig. 2.7. It is vitally important that the coupling bolt is fully tightened and the nut locked by means of a split pin, locking tab, or lock washer.

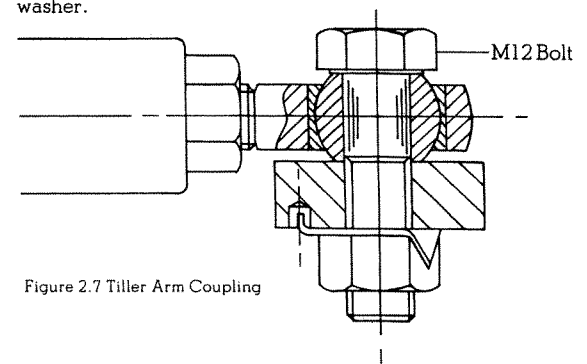

Figure 2.7 Tiller Arm Coupling

The grease lubricated gearbox permits mounting of the drive unit in any convenient attitude without risk of oil leakage. The drive unit's sprocket may also face any direction, since steering sense can be corrected by means of a phase switch located in the control unit.

Finally, the chain should be tensioned until it is 'just' tight and contributes negligible lost motion to the drive system. Total lost motion between the driven sprocket attached to the steering system and the rudder stock should not exceed 5% of total movement. If lost motion exceeds this level, it should be corrected, otherwise steering performance will be impaired.

2.2.2 Linear Drive Unit

The Linear Drive Unit couples directly to the rudder stock at the couple radius recommended in Fig. 2.6

It is usually preferable to couple the Linear Drive Unit to the rudder stock via an independent crank arm. In certain

The standard ball end fitting will allow for a maximum angular misalignment between the pushrod and the tiller crank plane of rotation of up to 5°. Accurate angular alignment is extremely important and under no circumstances should the above extreme limits be exceeded.

The body of the Drive Unit is mounted by bolting to a substantial frame member. As a general rule it is desirable to "over engineer" the Linear Drive Unit's mounting structure to ensure maximum reliability and maintenance of correct alignment.

It is important to ensure that the total rudder movement is limited by the rudder stops built into the vessel rather than the end stops or the Linear Drive Unit push rods.

2.3 Cabling and Power Supplies

2.3.1 Signal Cabling

Cable inter-connections between system sub-units are shown schematically in figs. 1.1, 1.2 and 1.3. The inter-connecting multi-core cable between the control unit and drive unit is 20feet (6m) long, and is supplied with the control unit. All other inter-connecting cables are supplied with their related sub-unit and are also 20feet (6m) in length. All 7core cables are supplied with pre-wired waterproof connectors and are extendible in 20feet (6m) increments by the addition of standard cable extensions (Cat. No.D59) as shown in fig. 1.3.

Cable connector clamp nuts should be securely tightened to ensure watertight joints. All cables should be run at least 3ft (1m) from existing cables carrying radio frequency or pulsed signals, and should be clamped at 1.5foot (0.5m) intervals.

2.3.2 DC supply cable

As a general rule the DC supply cable to the drive unit should be kept as short as possible, and have a conductor area of 1.0 sq mm per metre run to minimise voltage drop.

E.g. Length of cable	Conductor area	Cable size
Up to 2.5m	2.5 sq mm	50/0.25mm
Up to 4m	4 sq mm	56/0.3mm

The supply cable must run directly from the vessel's battery or alternatively from the main distribution panel, and a 20 amp fuse or current overload trip should be included in the circuit. It is important not to tap into supplies to other equipment to avoid the possibility of mutual interference.

Important: Drive units are supplied either for 12volt or for 24volt systems, and the two are not interchangeable.

The drive unit is supplied with 1.5ft (0.5m) power supply cable tails. These should be connected to the main power supply cable via a heavy-duty terminal block. The red cable tail should be connected to the positive supply. If polarity is accidentally reversed the equipment will not operate, but no damage will result.

If, as in rare cases, the vessel's negative supply is connected to a metal hull or engine frame, it is essential that the autopilot's negative supply cable be connected back to the negative supply at the main distribution panel. This will minimise the possibility of interference through loop returns.

The radio emission suppression circuit requires the drive unit case to be bonded to the metal hull or engine frame and a heavy-duty conductor should be used for this purpose.

3.0 Operation

3.1 Basic principles

The following description of the Autohelm 5000 principle of operation will help in providing a complete understanding of its controls. The control unit houses an extremely sensitive auto-setting electronic compass. When the autopilot is in operation, deviation from course is continuously monitored by the compass and corrective rudder is applied by the drive unit to return the vessel to course. The amount of applied rudder is proportional to the course error at any time, and thus when the original course is restored the rudder will be neutralised. The amount of rudder applied for a given off-course error is adjustable to match both the steering characteristics of the vessel and speed through the water. A vessel with a small rudder for example, will require more corrective helm than a similar sized vessel with a larger rudder. Similarly, a high speed power boat will require considerably less corrective helm at planing speeds than it will at lower displacement speeds.

The characteristic which distinguishes the Autohelm 5000 is its ability to make automatic correction for changes in trim or weather helm. When changes in trim occur the set course can only be maintained by the application of permanent rudder offset to restore balance. Many automatic pilots are incapable of this and will allow the vessel to bear on to a new heading to achieve a new state of balance. Under these circumstances the Autohelm 5000 detects that the original course has not been restored and will continue to apply additional helm in the appropriate direction until the vessel returns to the original heading. This facility ensures that the originally set course is held, irrespective of changes in balance that may occur during the course of a passage.

3.2 Controls

3.2.1 Control Unit

The accompanying illustration of the control unit shows the position of all controls.

Control Unit

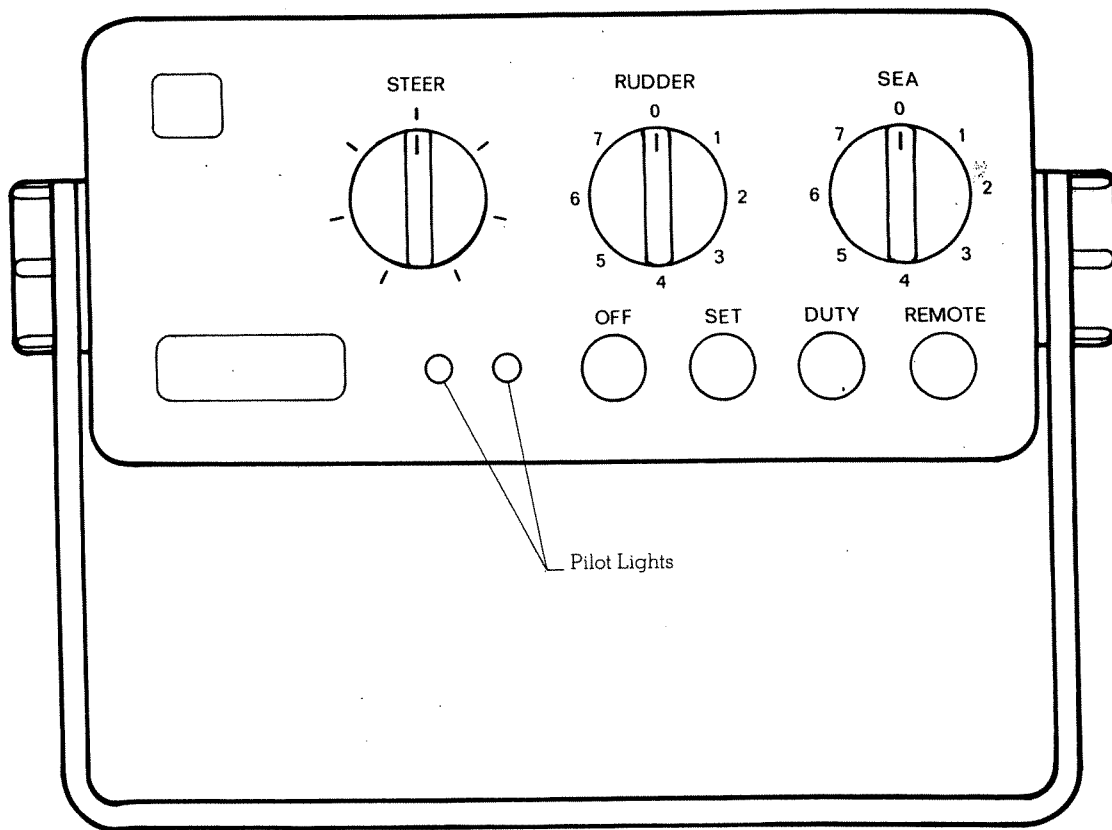

Each control has the following functions:

- OFF** —Push to de-energise the autopilot. The electromagnetic clutch in the drive unit is disengaged for manual steering.
- SET** —Push to energise the compass circuit and initiate the automatic compass setting sequence. The compass is finally set to the manually steered heading when both the red and green pilot lights are extinguished.
- DUTY** —Push to fully energise the autopilot for automatic steering duty.
- REMOTE** —Push to transfer basic automatic pilot control to the auxiliary control unit.
- SEA** —Rotate to adjust compass sensitivity to suit sea conditions. In position '0' the compass is fully sensitised for operation in calm sea

conditions. Clockwise rotation to position '7' progressively desensitises the compass for operation in rough sea conditions. Adjustment of this important control is fully discussed later.

- RUDDER** —Rotate to adjust rudder response. In position '0' rudder movement is minimised. Clockwise rotation to position '7' progressively increases the amount of applied rudder. Adjustment technique is fully discussed later.

- STEER** —Rotate counter-clockwise or clockwise to alter course to port or starboard respectively. Each scale division represents 5 degrees of course alteration. The steer control will rotate automatically when the control unit is switched to Set.

The controls on the rear case are used to adjust the autopilot's response to suit the particular installation and the vessel's steering characteristics.

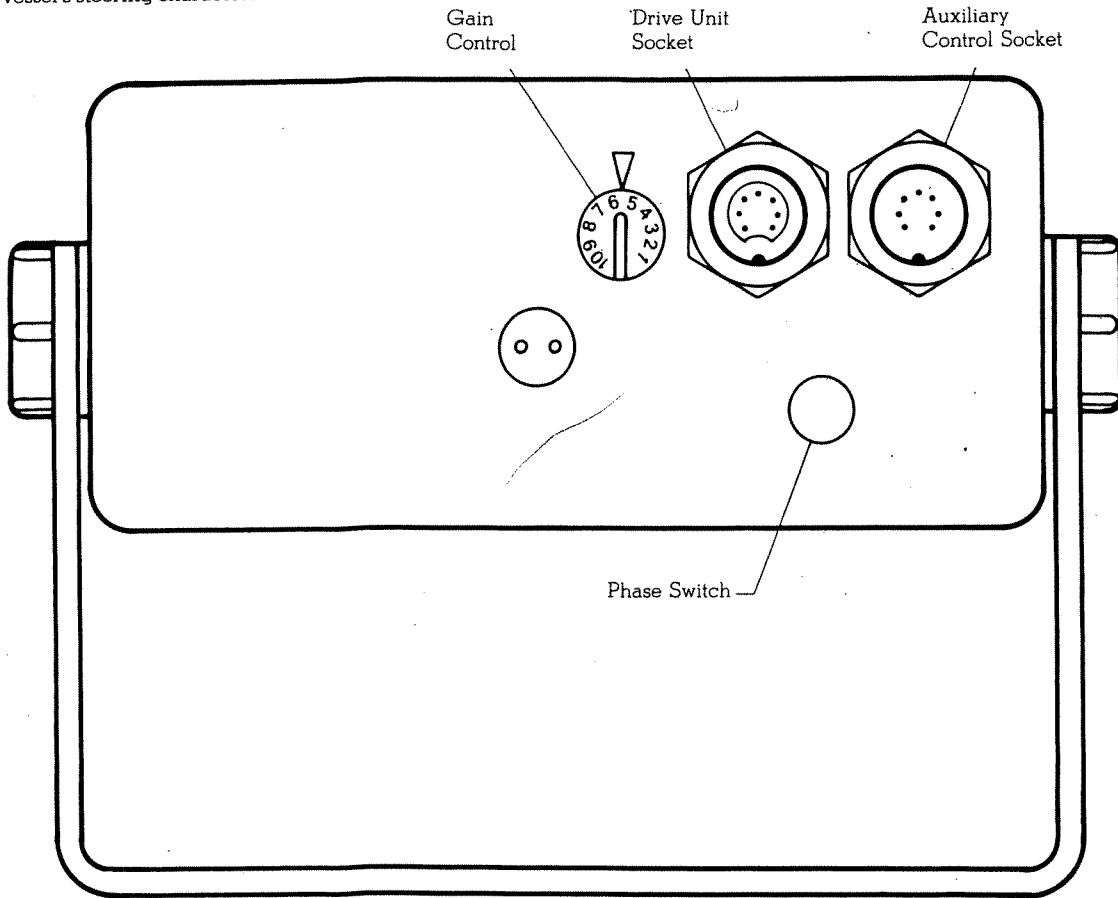

Each control has the following functions:

GAIN —Pre-sets the overall system gain to compensate for variations in the mechanical reduction between the drive unit and the rudder and the vessel's steering characteristics. For initial sea trial purposes this control is set according to the recommendations given in fig 3.1.

PHASE SWITCH —The phase switch is located on the internal PCB and is accessible by removal of a blank rubber grommet from the rear case. The phase switch reverses the direction of corrective rudder action and its setting procedure is described later.

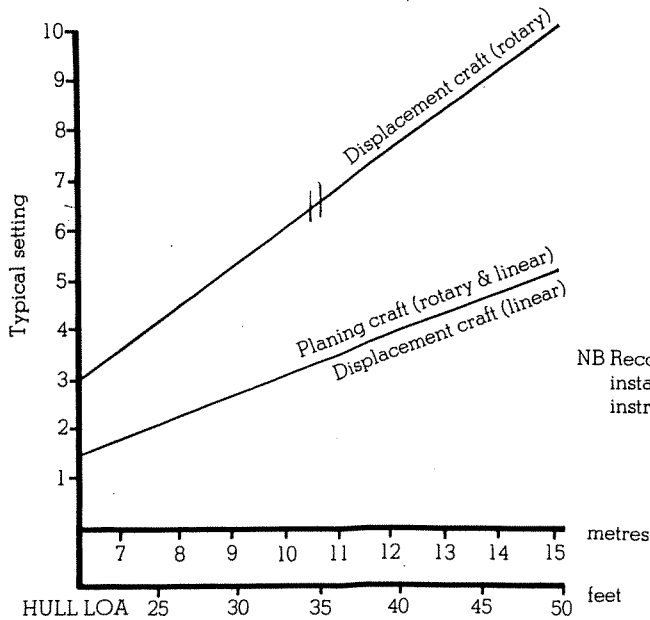

NB Recommended gain control settings for hydraulic drive installations are given in the hydraulic drive unit instructions. (supplied separately)

Figure 3.1 Gain Control Setting

3.2.2 Auxiliary Control Unit

Autopilot control may be transferred to the auxiliary control unit by depressing the **Remote** push-button on the main control unit fascia.

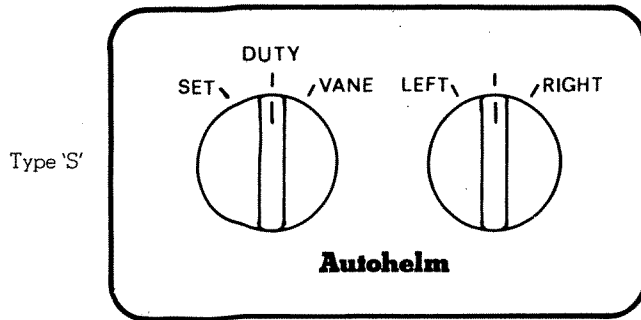

Auxiliary Control Unit

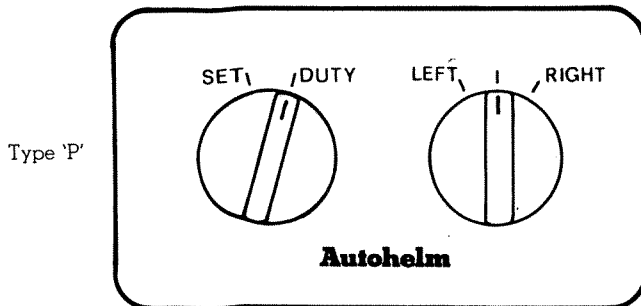

Two independent rotary switches are provided on the auxiliary control unit. The first permits change-over between **Set** and **Duty** modes. The sailing version provides a further switch position to change over to wind vane operation. The second control permits remote alteration of heading. Switch movement to the left or right initiates course alteration to port or starboard respectively at approximately one degree per second.

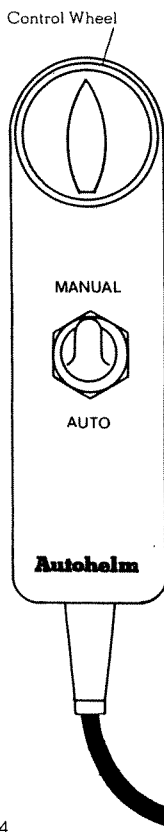

3.2.3 Remote Control Unit

The hand-held remote control unit enables the autopilot to be switched out and the vessel to be power steered from anywhere on board. Its flying lead may be plugged into any one of the remotely positioned waterproof sockets and should be switched to **Auto** for normal automatic steering operation. The autopilot may be overridden by switching to **Manual** and the vessel then power steered by means of the control wheel. The automatic trim system continues to operate in the manual steering mode and a straight course will be steered when the 'boat' on the control wheel is aligned with the remote control centre line. The original course is remembered and will be resumed immediately the change-over switch is returned to **Auto**. If the vessel has been power steered by the remote control for a long period it is important to check that there is no chance of collision when the original automatic heading is acquired by switching back to **Auto**.

Remote Control Unit

4.0 Functional test procedures

The following functional test procedure is recommended before attempting sea trials.

4.1 Main control unit

- Switch to **Set** and observe that the compass automatically sets to the present heading. The **Steer** control will rotate while the compass is setting and slow down as the null position is approached. When the compass is finally set both pilot lights will be extinguished.
- Switch to **Duty** and check that the drive unit clutch is engaged by attempting to rotate the steering wheel.
- Adjust the **Sea** and **Rudder** controls to '0'. Then adjust the **Steer** control one or two divisions clockwise and then counter-clockwise. The steering wheel should rotate in the same direction as the **Steer** control. If opposite wheel rotation occurs, reverse the phase switch. (A small screwdriver will be required to operate the phase switch after removal of the blank rubber grommet from the rear case).
- Increase **Rudder** control setting and note that larger wheel movements result when the **Steer** control is adjusted.
- Increase the **Sea** control setting and note that larger movements of the **Steer** control are necessary in either direction before steering wheel movement commences.

The automatic trimming capability of the autopilot can be observed by the following test:

Switch to **Set** to realign the compass. Then switch to **Duty** and offset the **Steer** control by approximately two divisions ie approximately 10 degrees of heading change. This effectively simulates a condition where the need for standing helm has developed and the vessel is not returning to course. You will notice that after an initial fixed helm has been applied the drive unit continues to apply further helm movements, but at a much slower rate. If left in this condition the wheel will eventually rotate hardover. If, however, the vessel is moving through the water the progressive application of additional helm will eventually return the vessel to its original course with the necessary standing helm applied. This can be simulated by rotating the steer control back to the original course position. The progressive application of standing helm will cease when the compass senses that the original course has been restored.

4.2 Auxiliary control unit

- Switch the auxiliary control unit to **Set** and then depress **Remote** on the main control unit. In this position the compass automatically sets to the present heading.
- Switch the auxiliary control unit to **Duty** and check that the drive unit clutch is engaged by attempting to rotate the steering wheel.
- Switch to **Vane** (sailing version only), and note that wheel movements are controlled by movements of the wind vane.

For this test, the wind vane should be feathered into wind by rotating its mounting mast so that the vane sets into a vertical position. After switching to **Vane** small variations in wind direction will cause corresponding movements of the steering wheel.

5.0 Sea trials

Initial sea trials should be carried out in calm conditions and with plenty of sea room. The previously conducted functional test will have verified that the autopilot is operating correctly and that you are familiar with all of its controls.

Check that the gain control on the rear of the control unit is adjusted to the setting recommended for the particular vessel category given in fig. 3.1. Then set the sea control to 'O' and the Rudder control to '4'.

Initial sea trials on fast planing vessels should be conducted at no more than half engine throttle under which conditions the recommended mid-way setting of the rudder control should give acceptable steering performance. A mid-way setting of the rudder control will also give acceptable steering performance in sailing and displacement power vessels under all conditions for initial trial purposes. Fine setting of the Rudder control is discussed later.

5.1 First trials

The following initial trial procedure is recommended:

- Steer manually on to a fixed heading and hold the course steady.
- Switch the autopilot to **Set** and allow up to 15 seconds for the compass to adjust automatically to the manually steered heading.
- Switch to **Duty** and the autopilot will automatically take control. In calm conditions an extremely constant heading will be maintained.
- Increase the setting of the **Sea** control until a good heading is achieved with a minimum number of wheel movements. Correct setting of this control for varying sea conditions is essential to avoid unnecessary wear and tear on the autopilot and to minimise electrical power consumption.
- Alter course to port or starboard using the **Steer** control on the main control unit, (or the **Left/Right** control on the auxiliary control unit with the main control unit switched to **Remote**). Major course alterations are best applied by switching to **Set** and then manually steering the vessel on to the new heading. When the new course is acquired, hold for a few seconds and then switch the autopilot back to **Duty** to maintain the new heading.
- If a hand-held remote control is fitted, switch from **Auto** to **Manual** and then power steer the vessel by the control wheel. Switch back to **Auto** and the vessel will return promptly to the original heading.
- When the autopilot is set to **Duty** return to manual steering may be instantly achieved by switching to **Set** or **Off** on the main control unit. It is very important to remember that manual control can only be obtained on the auxiliary control unit if the main control unit is switched to **Remote**. The importance of being able to regain manual control of steering must be stressed. The **Off** button is coloured red for easy identification and manual take-over procedures should be practised at an early stage.

5.2 Rudder control adjustment

The gain control on the rear of the control unit has been previously set according to the recommendation given in fig. 3.1. This control sets the range of adjustment available on the main panel **Rudder** control and in all but extreme cases should not need further adjustment.

In all cases, excessive rudder application results in 'oversteer' which can be recognised by the vessel swinging slowly from side to side of the controlled heading. In addition, distinct overshoot will be observed when the course is changed. This extreme condition may be corrected by reducing the **Rudder** control setting.

Similarly, insufficient rudder application will result in sluggish steering response which is particularly apparent when changing course using the **Steer** control. This condition is corrected by increasing the **Rudder** control setting.

Oversteering and understeering tendencies are most easily recognised in calm sea conditions where wave action does not mask basic steering performance.

The operational adjustment technique for the **Rudder** control varies significantly between planing and displacement craft and is described separately below.

5.2.1 Planing craft

Planing craft operate over a very large speed range. Rudder effectiveness increases very significantly at higher hull speeds and it is thus necessary to reduce the **Rudder** control setting as speed increases to avoid oversteer. In normal cases the rudder control setting would be reduced almost to 'O' at maximum planing speed and increased towards '7' at minimum displacement speeds. Oversteer can be extremely violent at planing speeds and it is thus essential to reduce the rudder setting before opening the throttle.

5.2.2 Displacement power vessels

The **Rudder** control setting is much less critical on this type of vessel and it is not normally necessary to change the setting for different engine speeds. As a general guide initial testing should be carried out at setting '4' and reduced as much as possible consistent with good heading control to minimise wear and tear on the steering system.

5.2.3 Sailing craft

Sailing craft average hull speeds do not vary greatly and thus the **Rudder** control setting can remain fixed most of the time. Initial testing should be carried out at setting '4'. Sailing craft, however, are particularly stable when sailing close hauled and under these conditions it is usually possible to reduce the **Rudder** control setting to minimise rudder movement and hence power consumption. Conversely, when sailing down wind, directional stability is least, and improved course holding will result from increasing the rudder setting. The optimum range of adjustment is easily found by experiment.

5.3 Setting the wind vane

The wind vane attachment enables a sailing craft to hold a constant heading relative to the wind. Wind vane control is particularly valuable when sailing close hauled since it enables optimised penetration to be maintained over long periods, even in backing wind conditions. Before the wind vane is set up it is advisable to switch the autopilot to compass duty to hold a steady course. The wind vane mast may then be rotated until the vane is feathered into wind. When perfectly set the vane will fly parallel to the mast, but may flutter slightly in turbulent conditions. A special damping circuit is built into the wind vane head to cope with this condition. Having set the wind vane, switch to **Vane** on the auxiliary control unit. The yacht will then settle on a constant heading relative to the wind. Alterations in heading are simply achieved by rotating the wind vane mast.

5.4 Tacking under wind vane control

In steady wind conditions the autopilot can be set up to enable the yacht to be tacked automatically by operation of the wind vane change-over switch on the auxiliary control unit. The wind vane should be set up to steer on the longest tack and the compass set to steer on the other. The yacht may then be tacked simply by operating the wind vane change-over switch leaving you free to handle the sheets.

6.0 Operating hints

Unlike sailing yachts, power vessels do not generally suffer with violent changes in trim, and thus, provided the operating instructions are carefully followed, extremely good course holding performance will result in all weather conditions.

Sailing yachts are very different since in gusting wind conditions violent changes in trim often occur. When a yacht is sailing badly out of balance, sudden gusts will generally cause it to luff violently to windward. When hand steering, the tendency is overcome by applying sufficient weather helm to maintain the original heading. The Autohelm 5000's automatic weather helm compensation circuit however, is intended only to take account of the gradual changes in standing helm that typically occur when passage making due to changing wind conditions.

When a sudden change in helm balance occurs the automatic compensation circuit will take approximately one minute to restore the original heading. In gusty conditions the course will tend to meander particularly if the sails are badly balanced. Significant improvement to course keeping can be obtained by ensuring that sail balance is maintained, and this may mean reefing the mainsail slightly more than you would normally when hand steering.

It is also worth mentioning the more obvious and that is that an autopilot cannot anticipate. Sailing downwind in breaking seas needs particular care.

One should avoid sailing under autopilot when the wind is dead astern. Ideally, the wind should be brought at least 30 degrees towards the beam, and in breaking seas it is often better to remove the mainsail altogether and to sail under boomed out headsail alone.

Providing you ensure that your vessel is properly canvassed for the prevailing conditions, your Autohelm 5000 will be capable of sailing you through gale force winds. Moreover, it is at times like this that it will endear itself most of all by leaving you fresh and alert to sail in safety.

Passage making under automatic pilot is a wonderful experience that can easily lead you into the temptation of relaxing permanent watch-keeping. This must be avoided however clear the sea ahead may appear to be. Remember, a large ship can cover two miles in five minutes — just the time it takes to brew a cup of coffee!

7.0 Routine maintenance

The autopilot is one of the most used and hardest working items of equipment on board and, therefore, must receive its fair share of attention and routine maintenance. The working parts of the drive unit and the control unit are sealed and lubricated during manufacture and will only need servicing after extended duty. It is recommended that both of these units are returned for checking and routine service by your appointed Service Agent after a maximum of 1000 hours operation, or two seasons use.

Regular inspection and routine maintenance of the installation is recommended in the following areas:

- 1 Check tension and alignment of the drive chain and lubricate with a good quality waterproof light grease.
- 2 Check for the development of excessive lost motion (backlash) in the steering gear and correct if necessary. Lost motion at the wheel should not exceed 5% of the total wheel movement from lock to lock.
- 3 Check that all inter-connecting cable sockets are fully tightened and free from corrosion.
- 4 Check that external waterproof sockets are capped when not in use and periodically spray with WD 40 (or similar) to protect from corrosion.
- 5 Check that the power supply cable connections are tight and free from corrosion.

The Autohelm 5000 has an advanced micro-electronic circuit requiring special equipment and knowledge to service. In the unlikely event of failure occurring in any part of the system you are advised to contact your nearest appointed Service Agent who will provide you with competent and efficient service.

Computer

F1

R

1

nautech ltd.

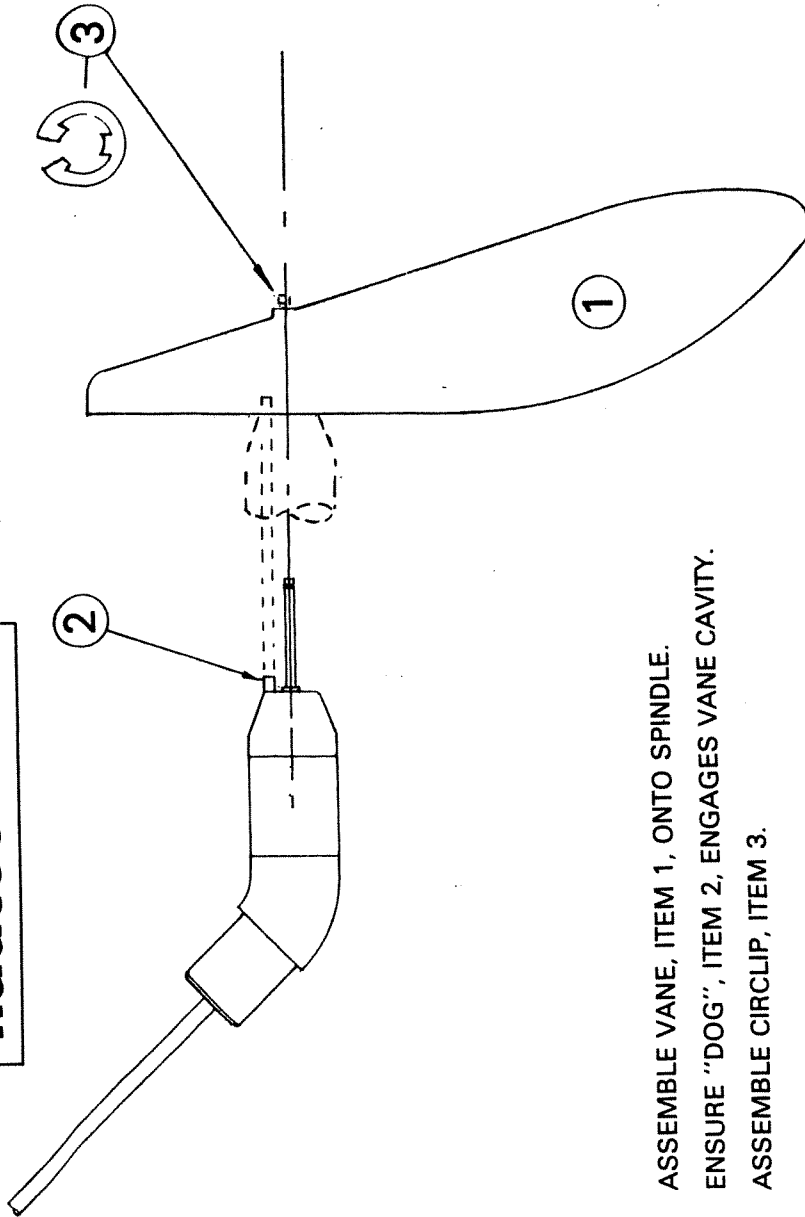

ASSEMBLE VANE, ITEM 1, ONTO SPINDLE.
ENSURE "DOG", ITEM 2, ENGAGES VANE CAVITY.
ASSEMBLE CIRCLIP, ITEM 3.

Nautech Limited
Anchorage Park
Portsmouth
Hampshire PO3 5TD
Portsmouth (0705) 693611
Telex: 86384 Nautech



nautech

Designed & produced by Jeavons Walker Design Printed in England

Electronic Wind Vane

Suitable for use with Autohelm 2000 and Autohelm 3000 Autopilots

Maintenance of optimum penetration when sailing hard on the wind requires a conflicting combination of sensitivity and vigilance. Most yachtsmen are aware how tiring this conflict can be on long windward passages.

Your Autohelm autopilot, operating under compass control, cannot sense wind shifts, and vigilance is still required when sailing to windward to maintain satisfactory penetration.

The electronic wind vane attachment monitors wind shifts continuously, ensuring that optimum penetration is doggedly maintained. Such consistent steering performance can often remove hours from long windward passages, and the wind vane can soon become your most respected crew member.



Type A
Standard 2000/3000
Installations
Type B
Porthand - 2000
Forward facing motor
- 3000

Autohelm

Installation

The electronic wind vane attachment consists of three modules – the mounting mast which elevates the wind vane into clear air, the transducer head which slots into the top of the mounting mast, and the vane itself which slots onto the pin on the transducer head, and is fixed in place by means of the circlip provided. The transducer head is connected electrically to the autopilot control unit, and the watertight jack plug and cable should be threaded down through the mounting mast.

The mounting mast is clamped onto either a horizontal or vertical rail of the after pulpit using the U clamps provided. If an after pulpit is not fitted the mast can be bolted directly onto a suitable vertical face. Care must be taken to ensure that the vane is in clear wind on either tack. This is normally ensured by situating the mounting mast centrally behind the backstay, and by elevating the vane at least 2feet (60cms) above the highest deck obstruction. On ketches the mounting mast is normally mounted onto the leading surface of the mizzen mast. It is important that the mast is mounted in a location where its base can be reached safely from the cockpit, to permit setting of the wind vane attachment.

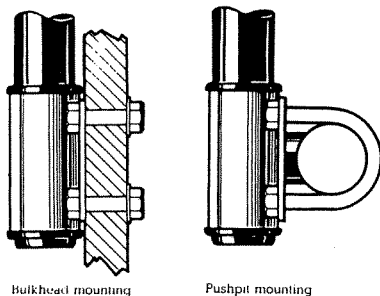

Functional Test Procedures

After completing the installation you should carry out the following functional tests.

Set up the Autohelm pilot whilst moored, so that the compass is set onto the boats heading. Switch the control unit to the No. 1 setting to activate the pilot.

Set the wind vane attachment by gripping the mounting mast just above its base, and slowly rotating until the vane feathers into the wind. The vane is feathered when it lies upright, in line with the mounting mast.

Insert the jack plug into the socket in the base of the autopilot control unit. The pilot should respond with a slight jerk on the helm when the plug is inserted. There should be no response to changes in course setting on the compass dial once the jack plug is inserted.

Observe that the smallest movement of the red vane causes the autopilot to apply corrective action on the rudder.

Switch the control unit to 2, and then to 3, and observe that progressively larger movements of the vane are required before the autopilot applies corrective rudder.

Operation Under Sail

Sail under autopilot control so that the boat is pointing 10 degrees less than its optimum windward penetration.

Rotate the wind vane mast until the vane is feathered. In strong winds the boat may be heeled, and it is important that the vane is feathered in line with the mounting mast, not into a vertical position.

Insert the jack plug into the socket in the base of the control unit. The boat should continue to sail on a similar course, but under wind vane control.

To bring the boat hard onto the wind rotate the mast gradually forward until the boat comes up hard onto the wind.

To bear away rotate the mast in the opposite direction whilst easing the sheets. Notice that only very small movements of the mast are required to trim course.

In rough weather, when vane flutter may start to occur, the resultant unnecessary helm corrections may be eliminated by increasing the sea state setting on the control unit.

To return to compass control simply remove the jack plug from the socket in the control unit, but remember to ensure that the correct course is set on the compass dial.

When the wind vane attachment is not in use, and the jack plug is disconnected, special care must be taken to ensure that the rubber blanking plug is pushed firmly into the socket on the base of the autopilot's control unit. This action together with occasional lubrication of the jack plug with silicone grease will prevent problems with water penetration into the control unit.

Specification

- Weather seal – Vane motion transmitted through hermetic seal by rare earth magnetic clutch.
- Sensitivity – Full control applied in wind strengths of Force 1 and above.
- Vane pick-up – Opto-electronic system with low impedance proportional voltage output.
- Materials – High impact ABS mouldings, HE 30TF marine grade aluminium alloy anodised to BS 1615-AA25 finish.

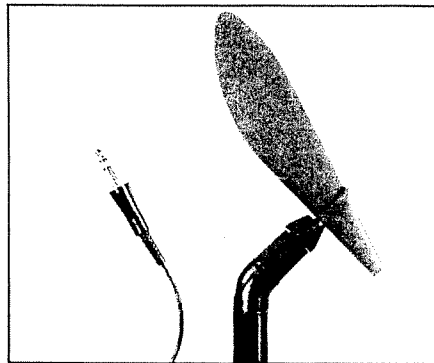

Nautech Limited
Anchorage Park, Portsmouth
Hampshire PO3 5TD
England
Portsmouth (0705) 693611